

IC660BBD020

Block 24/48Vdc Source I/O 16 Circuits, 3 Wire Sensor Compatible

Provides the wiring diagrams and installation guidelines for this GE Series 90-30 module.

16-Circuit Source/Sink I/O Blocks

April 2002

GFK-0043F

Description

A DC 16-Circuit Source/Sink I/O Block is an intelligent, configurable block that can interface to a wide range of discrete DC sensors and actuators.

There are two DC 16-circuit source blocks, which provide current to field output devices:

- **24 VDC Source block** (IC66*BBD022), for use with 2-wire and 3-wire solid state sensors and electromechanical sensors.
- **24/48 VDC Source block** (IC66*BBD020), for use with 3-wire solid state sensors and electromechanical sensors.

There are also two DC 16-circuit sink blocks, which receive current from field output devices:

- **24 VDC Sink block** (IC66*BBD023), for use with 2-wire and 3-wire solid state sensors and electromechanical sensors.
- **24/48 VDC Sink block** (IC66*BBD021), for use with 3-wire solid state sensors and electromechanical sensors.

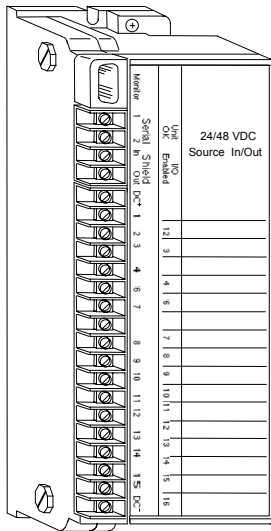

Features

DC 16-Circuit Source/Sink I/O Blocks have 16 discrete circuits, each easily configured to be an input, tristate input, or output. Output circuits can be connected directly to input circuits without the use of other components or inversion of logic states.

Control power is tapped off the input/output device voltages wired to the terminals. No separate block power supply is needed.

Configurable features include:

- Output Pulse Test capability
- Selectable Input Filter Time from 10ms to 100ms
- Output powerup defaults
- Output Hold Last State or default

The block's advanced diagnostics can pinpoint causes of installation and run-time errors. Diagnostics features of these blocks include:

- Electronic short circuit protection
- Overtemperature protection
- Failed switch detection
- Open wire detection for tristate inputs
- Overload detection and shutdown
- No-load detection

Specifications

Catalog Numbers			
24/48 VDC 16 Circuit Source I/O Block	IC66*BBD020		
Terminal Assembly only	IC66*TSD020		
Electronics Assembly only	IC66*EBD020 (same as block IC66*BBD022)		
24VDC Source 16 Circuit Source I/O Block	IC66*BBD022		
Terminal Assembly only	IC66*TB022		
Electronics Assembly only	IC66*EBD020 (same as block IC66*BBS020)		
24/48VDC 16 Circuit Sink I/O Block	IC66*BBD021		
Terminal Assembly only	IC66*TSD021		
Electronics Assembly only	IC66*EBD021 (same as block IC66*BBD023)		
24VDC 16 Circuit Sink I/O Block	IC66*BBD023		
Terminal Assembly only	IC66*TB023		
Electronics Assembly only	IC66*EBD021 (same as block IC66*BBD021)		
Block Specifications			
Size (height x width x depth)	8.83" (22.44cm) x 3.56" (9.05cm) x 4.42" (11.23cm)		
Weight	4 lbs. (1.8 kg)		
LEDs (I/O Block)	Unit OK, I/O Enabled		
LEDs (each circuit)	Individual load side indicators		
Block to block Isolation	1500V		
Heat Dissipation	68.8 Watts with 16 outputs on at 2A.		
Operating voltage (one source)	18-56 VDC (24/48 V), 18-30 VDC (24 V)		
Ripple (maximum)	10%		
Required DC power	150 mA typical/300 mA maximum		
Power supply dropout time	10ms		
Input Specifications			
For standard input, voltage relative to DC-	Source Blocks	Sink Blocks	
Input ON	24 VDC supply	16-24 VDC	0-8 VDC
	48 VDC supply*	32-48 VDC *	0-16 VDC*
Input OFF	24 VDC supply	0-7 VDC	17-24 VDC
	48 VDC supply*	0-14 VDC*	34-48 VDC*
Input processing time (typical)	5.6K Ohms (24/48V), 1.8K Ohms (24V)		
Input impedance (typical)	1.7ms (plus selectable filter delay)		
Selectable input filter times	5-100ms		
Input diagnostics	Open wire, Overtemp. Failed Switch		
Output Specifications			
Output current (steady state)	2 Amps per circuit		
Maximum inrush current	10 Amps up to 10ms		
Block output current	15 Amps at 35°C		
Output OFF leakage current	1.0 mA		
Maximum switching frequency	Once per second (high inrush current)		
Output turn-on delay (maximum)	1ms		
Output voltage drop	2.0 volts maximum at 2 Amps inrush		
Minimum Recommended Load	50 mA with No Load nabled		
Output Diagnostics	Short Circuit, Overload, No Load, Failed Switch, Overtemperature		
Environmental Specifications			
Operating Temperature	-0° to +60°C (32° to +140°F)		
Storage Temperature	-40 °C (-40° to +212°F)		
Humidity	5% to 95% (non-condensing)		
Vibration	5-10 Hz 0.2" (5.08mm) displacement, 10-200 Hz at 1G		

* for 24/48 VDC blocks

Refer to GFK-0867 for product standards and general specifications.

16-Circuit Source/Sink I/O Blocks

April 2002

GFK-0043F

Compatibility

These blocks are backward compatible with previous block versions of the same type. However, their Terminal Assemblies are not backward compatible. The Electronics Assembly can be used to replace an earlier Electronics Assembly of the same type.

The Terminal Assemblies of these blocks are *not compatible with some earlier versions of the Electronics Assemblies*.

Block Type	Terminal Assembly	Not Compatible with Electronics Assemblies
24/48 VDC Source Block (IC66*BBD020)	IC66*TSD020 (version C or later)	IC66*ELD020, any version IC66*EBD020, versions A to E
24 VDC Source Block (IC66*BBD022)	IC66*TBD022 (version B or later)	IC66*ELD020, any version IC66*EBD020, versions A to E
24/48 VDC Sink Block (IC66*BBD021)	IC66*TSD021 (version B or later)	IC66*EBD021, any version IC66*EBD021, versions A to D
24 VDC Sink Block (IC66*BBD023)	IC66*TBD023 (version B or later)	IC66*EBD021, any version IC66*EBD021, versions A to D

If the Terminal Assembly will be used to replace an earlier Terminal Assembly, and the Electronics Assembly is one of the incompatible versions listed above, the Electronics Assembly can be upgraded to make it compatible.

Any Hand-held Monitor can be used with these blocks. However, version IC66*HHM501 is required to change baud rate configuration, or to configure the block for redundancy.

For an IC697 series PLC, the CPU and programming software must be version 2.0 or later. The bus controller must be IC697BEM731C or later.

For an IC600 series PLC, the CPU must be rev. 105 or later. For an IC66* series Plus PLC, rev. 110 or later is required. The programming software must be rel. 4.02 or later. If the bus controller is model IC66*CBB900, it must be version C or later.

For an IC550 series PLC, the CPU must be rev. 3.0 or later. The programming software must be rel. 2.01 or later.

Using this Datasheet

This datasheet summarizes information about block installation, configuration, and diagnostics.

Your primary reference should be the *Discrete and Analog Blocks User's Manual*. It includes detailed instructions for block installation and configuration.

For additional information about systems and communications, including bus specifications, refer to the *I/O System and Communications Manual*.

Installation Instructions

Carefully inspect all shipping containers for damage. If any equipment is damaged, notify the delivery service immediately. Save the damaged shipping container for inspection by the delivery service. After unpacking the equipment, record all serial numbers. Save the shipping containers and packing material in case it is necessary to transport or ship any part of the system.

Block Mounting

Genius I/O blocks are considered "open equipment" and therefore must be installed within a protective enclosure. They should be located in an area that is clean and free of airborne contaminants. There should be adequate cooling airflow.

The block can be mounted right side up, or upside down. Leave at least 2 inches of space between blocks. Mount the block by drilling two screw or bolt holes for 8-32 hardware. Position the block so that the notches in the upper and lower flanges line up with the mounting holes. Mount the block using 8-32 screws. Use star washers to provide ground integrity.

Grounding

The block's mounting screws must not be used as the only means of grounding the block. Connect the green ground screw on the block to a reliable ground system using a short wire lead, minimum size AWG #12 (avg 3.3mm² in cross-section).

WARNING: If mounting screws do not make good ground connection and the ground screw is not connected to a reliable ground, the block is not grounded. Electrical shock hazard exists. Death or personal injury may result.

Block Wiring

All terminals accept one AWG #12 wire (avg 3.3mm² cross-section) or two AWG #14 wires (each avg 2.1mm² in cross-section). The minimum recommended wire size is AWG #22 (avg .36mm² in cross-section).

Block terminals can also accommodate spade or ring terminals up to 0.27 inch (6.85mm) wide with a minimum opening for a #6 screw, and up to 0.20 inch (5.1mm) depth from the screw center to the back barrier. Be sure unshielded wire ends are not longer than 2 inches (5 cm).

Do not overtorque the terminal screws. Recommended torque for all terminals is 6 in/lb (.678 N/M).

Serial Bus Wiring

Using one of the cable types recommended in the *System and Communications User's Manual*, connect the serial bus to terminals 1-4. (If a Bus Switching Module will be connected *directly* to the block, see below instead).

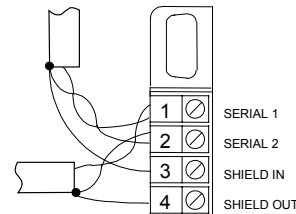

If the block is at either end of the bus, connect a terminating resistor of the appropriate type (see the *System and Communications User's Manual* for details) across its Serial 1 and Serial 2 terminals.

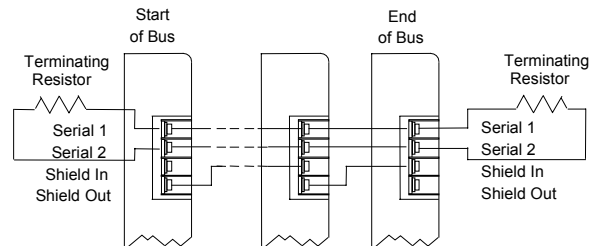

Wiring for a Bus Switching Module

If the block will be a BSM Controller, attach the Bus Switching Module to the block's serial bus terminals. Attach the serial bus cables to the BSM as described in the *Bus Switching Module datasheet*. Wire the BSM like a load to circuit 1. Connect either BSM pigtail wire to terminal 6. For a DC Sink block, connect the other BSM wire to DC+. For a DC Source block, connect the other BSM wire to DC.

Power Connections

Connect a DC power source to the DC+ terminal (5) and the return to the DC- terminal (22). Depending on the layout and current loads, positive and negative connections can be bussed and made by individual wires back to the block or power source.

16-Circuit Source/Sink I/O Blocks

April 2002

GFK-0043F

Connections for a DC Source Block

Any circuit can be an input or output. Connect one terminal of the device to the block (terminals 6-21). Connect outputs to DC- and inputs to DC+.

Connect outputs to the negative side of the power supply and inputs to the positive side. No logic inversion is needed.

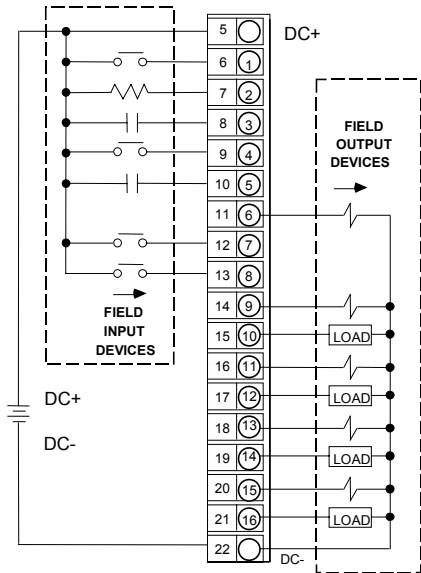

DC Source Block, Wiring for Tristate Inputs

If any input is configured as a Tristate Input, install a resistor across the dry contacts of the input device. This added resistance is required to use the Open Wire diagnostic. The LED will glow dimly as a result.

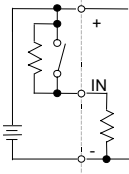

For a 24/48 VDC block, the resistor should be 5.1K Ohms, 1/2 Watt or larger. For a 24 VDC block, it should be 1.6K Ohms.

DC Source Block, Power Disconnects

It is important to wire block power disconnects so that block power and input power will be removed at the same time. Locate the power disconnect as shown below.

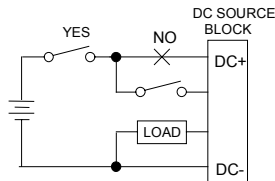

Caution: If circuit power is not removed at the same time as block power, the block may power up when multiple inputs are activated, even though one leg of power has been removed from the block.

Connections for a DC Sink Block

Any circuit can be an input or output. Connect one terminal of the device to the block (terminals 6-21). Connect outputs to DC+ and inputs to DC-

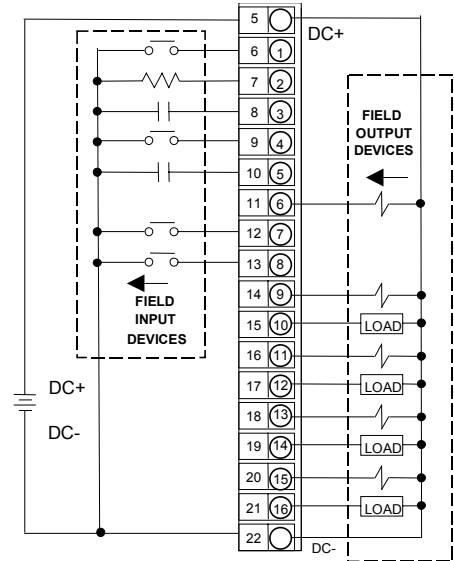

DC Sink Block, Wiring for Tristate Inputs

If any input is configured as a Tristate Input, install a resistor across the dry contacts of the input device. This added resistance is required to use the Open Wire diagnostic. The LED will glow dimly as a result. For a 24/48 VDC block, the resistor should be 5.1K Ohms, 1/2 Watt or larger. For a 24 VDC block, the resistor should be 1.6K Ohms.

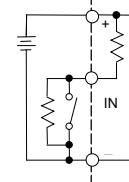

DC Sink Block, Power Disconnects

It is important to wire block power disconnects so that block power and input power will be removed at the same time. Locate the power disconnect as shown below.

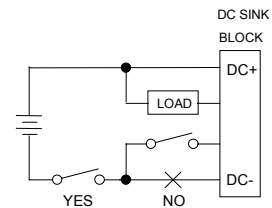

Caution: If circuit power is not removed at the same time as block power, the block may power up when multiple inputs are activated, even though one leg of power has been removed from the block.

16-Circuit Source/Sink I/O Blocks

April 2002

GFK-0043F

Removing an Electronics Assembly

The block's Electronics Assembly can be replaced with a compatible model without removing field wiring or reconfiguring the block.

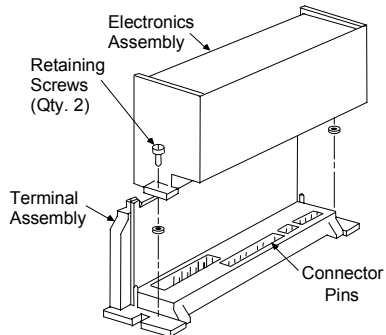

1. Unscrew the retaining screws at the top and bottom of the block.
2. Using a Block Puller (IC660BLM507), engage the tabs in the first vent slots. Move the tool to the center of the block and squeeze the handle.
3. Pull the Electronics Assembly upward.

WARNING: If power is applied to the field terminals, power is also exposed on the connector pins at the base of the Terminal Assembly, and electrical shock hazard exists. Do not touch the connector pins! Death or injury may result.

Inserting an Electronics Assembly

1. Align the Electronics Assembly in the guides and push down firmly.

CAUTION: Do not exert excessive force; it may damage the block.

2. If unusual resistance is met, remove the Electronics Assembly. If power is applied to the block, DO NOT TOUCH THE CONNECTOR PINS! Inspect the Terminal Assembly, connector receptacle, and connector edge board (on the Electronics Assembly). Be sure the keying matches. Remove any obstacles and reinsert the Electronics Assembly. Pay close attention to the alignment of the guide pins.
3. Secure the Electronics Assembly with the screws on the top and bottom of the Terminal Assembly.

Replacing an Older Electronics Assembly

If the Electronics Assembly (IC66*EBD020 or EBD021) will replace Electronics Assembly model IC66*ELD020 or ELD021 (only), follow the steps below. Otherwise, some inputs may operate incorrectly.

1. BEFORE REMOVING THE OLD ELECTRONICS ASSEMBLY FROM THE TERMINAL ASSEMBLY connect a Hand-held Monitor to the block.
2. If there is any other HHM currently connected anywhere to the bus, it must be disconnected (not just turned off).
3. Power up the HHM and proceed to the Block/Bus Status menu. Select the block as the "active" block on the HHM.
4. Proceed to the MNTR/CNTL REF menu. Then:
 - A. Monitor one of the first eight circuits on the block (for example, circuit #1). Press the RELEASE key.
 - B. Monitor one of the second eight circuits on the block (for example, circuit #9). Press RELEASE.
5. Press the Hand-held Monitor OFF key and disconnect the HHM from the block.
6. Power down the block. Remove the Electronics Assembly.
7. Insert the new Electronics Assembly. Power up the block.

If the new Electronics Assembly was installed without following these steps and the block is powered up, inputs may be operating incorrectly. **Connect a Hand-held Monitor and follow the procedure described above.**

Block Operation

Each circuit can be configured as an input, a tristate input, or an output. If the block is configured as a combination block, output feedback is provided via the corresponding input references.

16 Circuit DC Source I/O Blocks

A DC source block has all output devices connected to the negative (-) side of the power supply. Inputs control the positive (+) side.

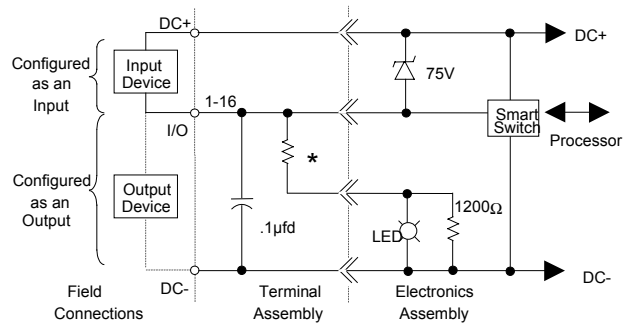

* 5.6K ohms for 24/48 VDC blocks.
1.8K ohms for 24 VDC blocks

16 Circuit DC Sink Blocks

A DC sink block has all output devices externally connected to the positive (+) side of the power supply. Inputs control the negative (-) side.

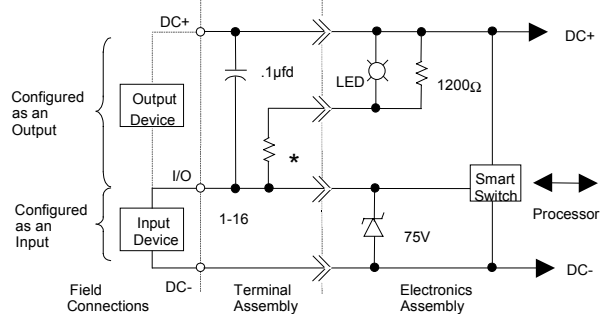

5.6K ohms for 24/48 VDC blocks.
1.8K ohms for 24 VDC blocks

LEDs

The Unit OK and I/O Enabled LED's show the operating status of the block.

Unit OK	I/O Enabled	Meaning
ON	ON	Block functioning, CPU communicating
ON	OFF	Block functioning, No CPU communications for 3 bus scans
ON	Blinking	Block functioning, Circuit forced
Blinking	ON	Circuit fault, CPU communicating
Blinking	OFF	Circuit fault, No CPU communications for 3 bus scans
Alternate Blinking		Circuit fault, Circuit forced
Synchronous Blinking		No CPU communications - block number conflict
OFF	OFF	No block power, or block faulty

Circuit LEDs

Each circuit has its own LED. If the circuit is configured as an input, the LED indicates the presence of threshold voltage at the input terminal. If

16-Circuit Source/Sink I/O Blocks

April 2002

GFK-0043F

the circuit is configured as an output, the LED indicates the actual state of the load.

Diagnostics

The block always performs its standard diagnostic checks, plus two configurable output diagnostics. The block reports all faults to the Hand-held Monitor, and takes appropriate corrective action.

Short Circuit Diagnostic (standard) If the instantaneous current exceeds 10 Amps at turn-on, the block turns the output off. The block attempts to restart the load; if two attempts are unsuccessful, the output circuit is forced off and the block sends a SHORT CIRCUIT message. The cause of the current surge must be removed, then the diagnostic must be cleared from the HHM or the CPU.

Overtemperature Diagnostic (standard) If the block's internal temperature exceeds 100° C, the block sends an OVERTEMPERATURE message and turns off the circuit to protect its internal electronics.

Failed Switch Diagnostic (standard) For an output, Failed Switch is reported if the circuit's switch state is not the same as its commanded state. The block sends a FAILED SWITCH message identifying the failed circuit. The logic state of the circuit is set to OFF. If the output switch has failed shorted (or closed), current flow is not interrupted when the block forces the output state OFF. Action external to the block must be taken to remedy the problem.

Several additional switch faults independent of the output state are detected and reported as Failed Switch faults on both input and output-configured circuits. Examples include loss of communications with the block's internal microprocessor and some internal power supply faults.

Note that in GMR applications, Failed Switch operates differently. See the *GMR User's Manual* for details.

Open Wire Diagnostic (standard) Indicates electrical (not mechanical) malfunctions on a tristate input. The circuit must have a non-inductive resistor placed as close as practical to the actual dry contacts (such as across the field device terminals), as shown previously.

Overload Diagnostic (configurable) If Overload Shutdown is enabled, the block will turn the output off and send an OVERLOAD message if a load exceeds 2.8 Amps DC continuously for 10ms. currents. Exceeding these limits may cause an overtemperature fault.

A load that requires more than 2 Amps DC can be configured not to shut off at this level or send the OVERLOAD message.

No Load Diagnostic (configurable) If a load does not continuously draw 50mA from the output circuit, the block sends a NO LOAD message. A No Load condition may cause an HHM monitoring the block to display 0 for the circuit although there is voltage at the output and the circuit LED is on. This diagnostic should be not be used for circuits on which very small loads (small relays, transformers, or indicating lamps) will draw less than 50 mA.

Note that in GMR applications, No Load operates differently. See the *GMR User's Manual* for details.

Configuration

First, the block must be configured with a Hand-held Monitor to:

- Enter its Device Number (serial bus address).
- Enter its Reference Number (required only for IC600 and IC550 series PLCs only).
- In addition, unless all circuits on the block will be inputs, the Block I/O Type must be set to either Outputs or Combination on the *Program Block ID* screen.

Note: If a block is configured offline, it must be properly grounded and have a 75 Ohm resistor installed across its Serial 1 and Serial 2 terminals. See the *Discrete and Analog I/O Blocks User's Manual* for instructions. The rest of the features can be configured either using a Hand-held Monitor, or by sending a Write Configuration datagram to the block from the host.

Feature	Circuit or Block	Factory Setting	Selections
Baud Rate	B	153.6 std	153.6 std, 153.6 ext, 76.8, 38.4
Block I/O Type	B	input	input, output, combination
Pulse Test	B	enabled	enabled, disabled
Input Filter Time	B	20 msec	10-100 msec
Circuit I/O Type	C	input	input, output, tri-state input
Report Faults	C	yes	yes, no
Hold Last State	C	no	yes, no
Output Default State	C	off	on, off
Report No Load	C	yes	yes, no
Overload Shutdown	C	yes	yes, no
BSM Present	B	no	yes, no
Output Timeout	B	3 bus scans	2.5, 10 seconds
Redundancy Mode	B	none	none, standby, dup., GMR
Duplex Def. State	B	off	on, off
Config. Protect	B	disabled	enabled, disabled